



# StreamLine

**YAKIMA**<sup>®</sup>  
TAKE IT EASY.



## What's Inside?

### INTRODUCTION 3

Introduction	3
Our History	4
Testing and Validation	6



### STREAMLINE 8

StreamLine Overview	8
System Components	10



### INSTALLATION 12

BaseLine System	12
SkyLine System	13
SightLine System	14
TimberLine System	15
Toe & Pitch	16
Measurements	17
BaseLine Legs	18
SkyLine Legs	20
SightLine Legs	22
TimberLine Legs	24
Accessories	26



## WE DON'T HAVE WILD SIDES, WE HAVE WILD SOULS.

Our story is more of a journey, because we've never been good at sitting still. After all, we don't have wild sides; we have wild souls. For nearly four decades, our trusted solutions have transformed the way people travel. We're leaders in our category, packing heritage, safety, design sensibility, and street smarts into every product. Based in Brisbane, we've got the great outdoors at our doorstep. From valleys and peaks to banks and backlands, the grounds we roam make us feel at home. Together with our network of respected retailers, we give everyone the freedom to wander, the right to be unruly, and the confidence to go more rogue.

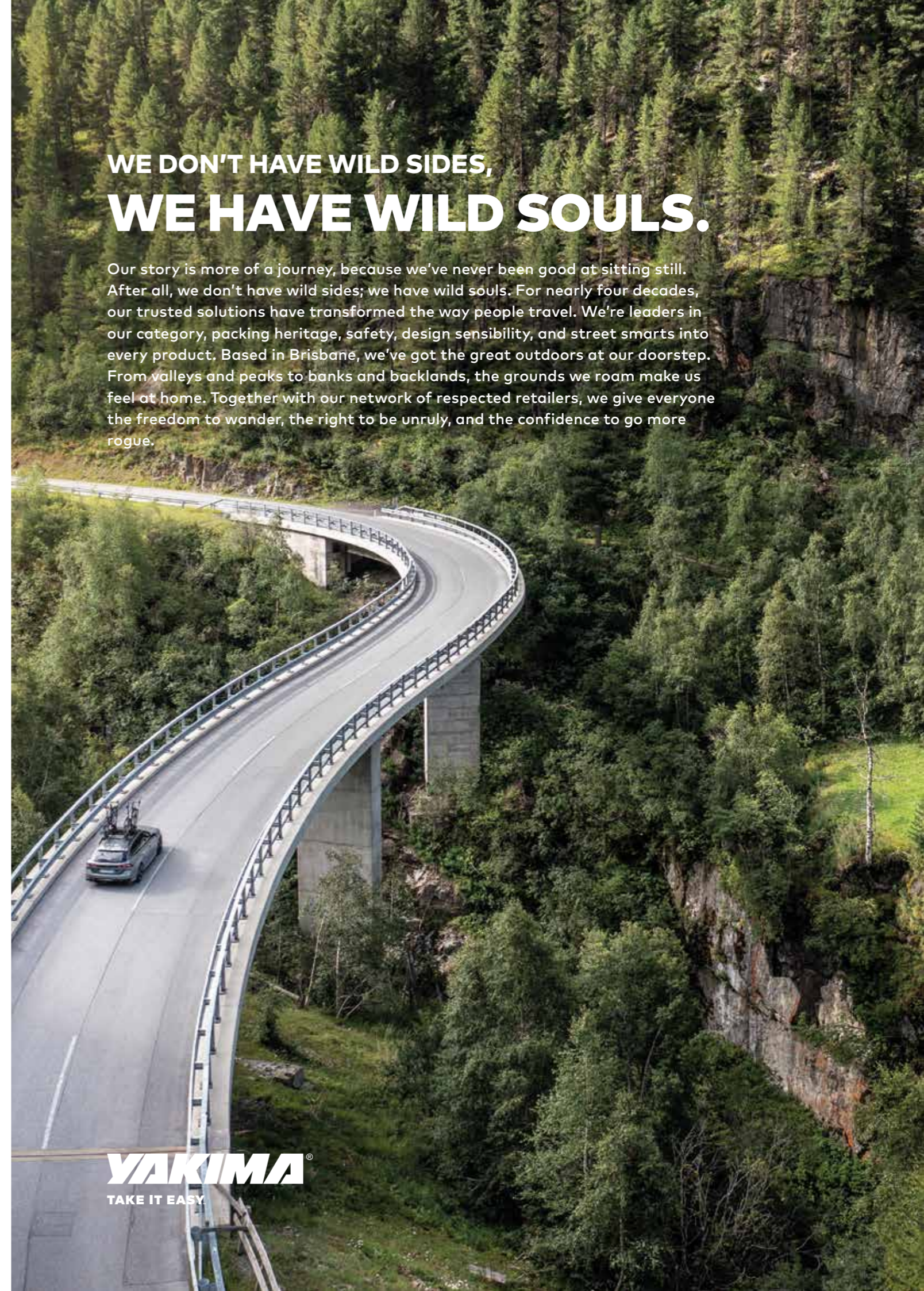

**YAKIMA**  
TAKE IT EASY



# From Local River Rats To Mainstream Movers And Shakers

Yakima has a history of making bold moves in the name of new horizons. We started as a small machine shop in our namesake city in Washington State. Then in 1979, Steve Cole and Don Banducci, hardcore kayakers and cyclists, acquired the company. These nature-chasing game-changers set out to take their own unwieldy gear further.

By 1984, they put Yakima on the map at the Summer Olympics, decking out every race vehicle with original aerodynamic fairings. It wasn't long before Yakima became an international symbol for playing more and wrangling less.

Today, we continue to lead the niche we helped establish so many decades ago, with the same enthusiasm, right around the world.



*Campagnolo. The most prestigious name in cycling. All U.S. Campy Tech Support vehicles run with Yakima.*





# Testing And Validation Standards

## PUTTING OUR PRODUCTS TO REAL-WORLD AND SCIENTIFIC TESTING

### THE RIGHT FIT

Our dedicated in-house team has committed itself to fitting vehicles of all shapes, makes and sizes to ensure we engineer secure, comprehensive, easy-to-install rack solutions dialled to specifically fit almost every vehicle on the road today - yours included.



#### WHAT DOES TESTING MEAN TO YAKIMA?

Yakima has been testing racks since 1979, basically since before there was an industry to create test standards. Because of this, we have a long history of developing and challenging our own internal test standards and procedures.

It starts in our lab. We beat stuff up and stress it out—the whole unit and each of the parts that make it up. Then we hit the road. Load it, use it, abuse it, fix it and refine it over and over again until we're totally confident in its performance.

On top of continuously pushing our internal standards, we also incorporate external industry standards as they develop, such as:

- ISO 11154 Roof Load Carriers
- DIN 75-302 Roof Racks for Passenger Cars
- ISO City Crash
- ASTM G154-00-UV
- ASTM D3359-Paint
- ISTA 1C-Packaging

And while these industry standards are good, they're not enough to ensure products are up to Yakima's high performance expectations. Know that any Yakima rack that hits the market has gone through and survived the rigours of our official in-house wringer.



## Types Of Testing

### STATIC TESTING

We perform static pull testing to meet or exceed ISO and DIN requirements in addition to our internal standards. These tests pull the gear in all directions—up, down, forward, back, sideways and at an angle. The pull forces vary based on product and direction to simulate the dynamic loads that a rack experiences while the vehicle is driving. They also simulate the aerodynamic loads that happen when a vehicle is cruising down the highway with little regard for speed limits.

### DYNAMIC TESTING

Dynamic testing is performed on a single-axis purpose-built shaker and a six-axis MOOG shaker. The shakers simulate driving over different types of rugged road surfaces, and can focus on specific frequencies that accelerate wear. They are really cool.

### ROAD TESTING

We take on speed bumps, speed humps, potholes, gravel and washboard surfaces. Then we throw in emergency stops, swerves, excessive speed and more. Some of the course features are industry standards, but many are Yakima internal tests. And, yes, it's really fun.

### ENVIRONMENTAL TESTING

We also test each product for weather resistance, including temperature, corrosion, UV and ozone. These tests ensure that the product will work in all conditions, and continue to work well for years on your vehicle.

### ADDITIONAL TESTING

And there's more... we also test for other performance attributes to make sure our products meet our high expectations.

- Security – Testing to ensure security and theft resistance
- ISO City Crash – 8g to 12g dynamic test to simulate a crash situation
- Impact – To ensure resistance to impact from flying objects or from dropping the product
- Paint and Decal Adhesion – To make sure the paint and decals are durable
- RoHS and REACH - To ensure materials used in the products do not contain certain harmful substances and are safe for our consumers and environment
- Usability – Making sure our product is easy and safe to use as intended
- User Field Testing – Getting products in use by real people in the real world



#### WHAT DOES THIS MEAN FOR YOU?

By creating and testing to a standard above what's required, we've established a reputation for having the most rugged and secure racks on the market. When you sell a Yakima product to your customer, you'll know that it has been validated for the highest level of quality on the market.





# The StreamLine Collection

THE TOUGHEST AND MOST ADVANCED ROOF RACK SYSTEM, EVER.



The StreamLine system combines advanced aerodynamics and clean lines with exceptional strength and versatility. Three crossbar styles and eight leg designs are available to create a system that fits your life and carries all the gear you need.

- Includes aerodynamic JetStream, JetStreamFX or heavier duty TrimHD crossbars with T-Slot and SmartFill pushdown infill for easy accessory mounting.
- Sleek StreamLine legs with a textured matte finish showcasing a debossed Yakima polished logo to give it a premium finish.
- A seamless visual connection to the style of your vehicle.
- Durability, versatility, and ease of use that's totally Yakima.

## FOUR SLEEK, MODERN STREAMLINE LEG STYLES, EACH DESIGNED FOR YOUR SPECIFIC ROOF TYPE...

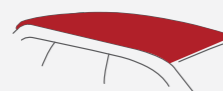
**1.**   
FOR NAKED ROOFS

↓



**BaseLine**    **BaseLineFX**    + Vehicle specific BaseClips

**2.**   
FOR FIXED POINT ROOFS

↓



**SkyLine**    **SkyLineFX**    + Vehicle specific Landing Pads

**3.**   
FOR RAISED RAIL ROOFS

↓



**TimberLine**    **TimberLineFX**

**4.**   
FOR FLUSH RAIL ROOFS

↓



**SightLine**    **SightLineFX**    + Vehicle specific SightClips

## Crossbar Type



### JETSTREAM FX BAR (FLUSH)

- FX for a flush connected look to your vehicle
- T-slot with SmartFill™ push-down infill makes adding your gear and accessories super-fast and easy
- Wing shaped bar profile creates aerodynamic design for reduced wind noise
- Built to last, with engineered light aluminium construction and durable powder-coat or anodised silver finish
- Rated for a maximum of 75 kg\* per pair
- Available in black or silver



### JETSTREAM BAR (THROUGH)

- Through Bar for extra carrying width
- T-slot with SmartFill™ push-down infill makes adding your gear and accessories super-fast and easy
- Wing shaped bar profile creates aerodynamic design for reduced wind noise
- Built to last, with engineered light aluminium construction and durable powder-coat or anodised silver finish
- Rated for a maximum of 75 kg\* per pair
- Available in black or silver



### TRIMHD BAR (THROUGH)

- Built tough to last, with engineered light aluminium construction and durable powder-coat finish
- Features integrated tie-down points - with a low visibility blackened finish
- Standard-sized T-slots makes adding your gear and accessories super-fast and easy
- Load strips with airflow diffuser ridge helps with load carrying and reduces wind noise
- Rated for a maximum of 100 kg\* per pair.
- Available in black



\* Max. load rating is dependent on vehicle's roof and fit load restrictions

## The StreamLine Fit Finder



THE QUICK AND EASY WAY TO FIND THE BARS, LEGS & KIT THAT MATCH YOUR CAR

Visit our vehicle fit finder page to find your fit

1. Scan the QR code for your region
2. Enter vehicle details
3. The Yakima fit-finder will show all of the compatible roof rack options.

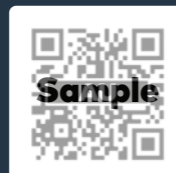

### COMPONENTS OF A STREAMLINE ROOF RACK SYSTEM



#### CROSSBAR

There are 3 styles to choose from and this is where a variety of gear mounts will attach.

- JetStream FX
- JetStream
- TrimHD

#### LEG

Legs attach to the vehicle to form the base of the rack system. There are 4 kinds of legs available in 2 styles, Through and FX, designed for different roof types.

- BaseLine & BaseLine FX
- SightLine & SightLine FX
- SkyLine & SkyLine FX
- TimberLine & TimberLine FX

#### CLIP/LANDING PAD

BaseLine and SightLine legs require a vehicle specific "clip". This holds the legs to the vehicle. SkyLine requires a vehicle specific Landing Pad.

- BaseLine - BaseClip
- SightLine - SightClip
- SkyLine - Landing Pad



# Leg & Fit components

## BaseLine System

DESIGNED STRONG, FOR NAKED ROOFS



## SkyLine System

QUICK RELEASE AND LOW PROFILE



### BaseLine Legs

#### INSTALLATION HARDWARE

- BaseClips - vehicle specific sold separately
- Easy installation with included torque tool

#### CROSSBAR COMPATIBILITY

- JetStream Bars (Through)
- TrimHD Bars (with TrimHD Adapter)

#### COMPETITIVE EDGE

- Pitch and tow adjustments to mimic the curvature of a vehicle's roof for a stronger and even better aerodynamic fit
- Tough steel chassis with high rust resistant black zinc nickel coating
- Fully adjustable to ensure strong fit and to accommodate a large range of naked roof shapes
- Made from durable ASA plastic for high wear and weather resistance
- All components REACH and RoHS compliant

#### LOCKING

- Easily locks with included SKS

#### LOAD LIMIT

- BaseLine Legs + JetStream Through Bar load limit 75 kg per pair (depending on vehicle fit and roof limit)
- BaseLine Legs + TrimHD Bar load limit 100 kg per pair (depending on vehicle fit and roof limit)

### BaseLine FX Legs

#### INSTALLATION HARDWARE

- BaseClips - vehicle specific sold separately
- Easy installation with included torque tool

#### CROSSBAR COMPATIBILITY

- JetStream FX Bars

#### COMPETITIVE EDGE

- Complements your vehicle's aerodynamic attitude
- Pitch and tow adjustments to mimic the curvature of a vehicle's roof for an even better aerodynamic fit
- Tough steel chassis with high rust resistant black zinc nickel coating
- Fully adjustable to ensure strong fit and to accommodate a large range of naked roof shapes
- Made from durable ASA plastic for high wear and weather resistance
- All components REACH and RoHS compliant

#### LOCKING

- Easily locks with included SKS
- Locks are hidden for a more aesthetically pleasing look

#### LOAD LIMIT

- BaseLine FX Legs + JetStream FX Bar load limit 75 kg per pair (depending on vehicle fit and roof limit)

### SkyLine Legs

#### INSTALLATION HARDWARE

- Landing Pads - vehicle specific sold separately
- Easy installation with included torque tool

#### CROSSBAR COMPATIBILITY

- JetStream Bars (Through)
- TrimHD Bars (with TrimHD Adapter)

#### COMPETITIVE EDGE

- Once installed, the entire rack is easy to remove and reattach tool-free
- Bar angle adjusts for better accessory attachment and aerodynamics
- Durable and strong cast steel chassis
- Made from durable ASA plastic for high wear and weather resistance
- All components REACH and RoHS compliant

#### LOCKING

- Easily locks with included SKS

#### LOAD LIMIT

- SkyLine Legs + JetStream Through Bar load limit 75 kg per pair (depending on vehicle fit and roof limit)
- SkyLine Legs + TrimHD Bar load limit 100 kg per pair (depending on vehicle fit and roof limit)

#### VEHICLE ROOF TYPE

- Factory fixed points, Track installations, Custom install

### SkyLine FX Legs

#### INSTALLATION HARDWARE

- Landing Pads - vehicle specific sold separately
- Easy installation with included torque tool

#### CROSSBAR COMPATIBILITY

- JetStream FX Bars

#### COMPETITIVE EDGE

- Complements your vehicle's aerodynamic attitude
- Once installed, the entire rack is easy to remove and reattach tool-free
- Bar angle adjusts for better accessory attachment and aerodynamics
- Durable and strong cast steel chassis
- Made from durable ASA plastic for high wear and weather resistance
- All components REACH and RoHS compliant

#### LOCKING

- Easily locks with included SKS
- Locks are hidden for a more aesthetically pleasing look

#### LOAD LIMIT

- SkyLine FX Legs + JetStream FX Bar load limit 75 kg per pair (depending on vehicle fit and roof limit)

#### VEHICLE ROOF TYPE

- Factory fixed points, Track installations, Custom install

## SightLine System

COMPLEMENTS YOUR VEHICLES AERODYNAMIC ATTITUDE



### SightLine Legs

#### INSTALLATION HARDWARE

- SightClips - vehicle specific sold separately
- Easy installation with included torque tool

#### CROSSBAR COMPATIBILITY

- JetStream Bars (Through)
- TrimHD Bars (with TrimHD Adapter)

#### COMPETITIVE EDGE

- Pitch and tow adjustments to mimic the curvature of a vehicle's roof for a stronger and even better aerodynamic fit
- Tough steel chassis with high rust resistant black zinc nickel coating
- Made from durable ASA plastic for high wear and weather resistance
- All components REACH and RoHS compliant

#### LOCKING

- Easily locks with included SKS
- Locks are hidden for a more aesthetically pleasing look

#### LOAD LIMIT

- SightLine Legs + JetStream Through Bar load limit 75 kg per pair (depending on vehicle fit and roof limit)
- SightLine Legs + TrimHD Bar load limit 100 kg per pair (depending on vehicle fit and roof limit)

### SightLine FX Legs

#### INSTALLATION HARDWARE

- SightClips - vehicle specific sold separately
- Easy installation with included torque tool

#### CROSSBAR COMPATIBILITY

- JetStream FX Bars

#### COMPETITIVE EDGE

- Complements your vehicle's aerodynamic attitude
- Pitch and tow adjustments to mimic the curvature of a vehicle's roof for a stronger and even better aerodynamic fit
- Tough steel chassis with high rust resistant black zinc nickel coating
- Made from durable ASA plastic for high wear and weather resistance
- All components REACH and RoHS compliant

#### LOCKING

- Easily locks with included SKS
- Locks are hidden for a more aesthetically pleasing look

#### LOAD LIMIT

- SightLine FX Legs + JetStream FX Bar load limit 75 kg per pair (depending on vehicle fit and roof limit)

## TimberLine System

SECURE, QUIET, AND SIMPLE TO INSTALL



### TimberLine Legs

#### INSTALLATION HARDWARE

- Easy installation with included torque tool

#### CROSSBAR COMPATIBILITY

- JetStream Bars (Through)
- TrimHD Bars (with TrimHD Adapter)

#### COMPETITIVE EDGE

- No extra hardware; the rubber coated metal band wraps around the rail with included tool
- Tough steel chassis with high rust resistant black zinc nickel coating
- Made from durable ASA plastic for high wear and weather resistance
- All components REACH and RoHS compliant

#### LOCKING

- Easily locks with included SKS

#### LOAD LIMIT

- TimberLine Legs + JetStream Through Bar load limit 75 kg per pair (depending on vehicle fit and roof limit)
- TimberLine Legs + TrimHD Bar load limit 100 kg per pair (depending on vehicle fit and roof limit)

### TimberLine FX Legs

#### INSTALLATION HARDWARE

- Easy installation with included torque tool

#### CROSSBAR COMPATIBILITY

- JetStream FX Bars

#### COMPETITIVE EDGE

- Complements your vehicle's aerodynamic attitude
- Tough steel chassis with high rust resistant black zinc nickel coating
- Made from durable ASA plastic for high wear and weather resistance
- All components REACH and RoHS compliant

#### LOCKING

- Easily locks with included SKS
- Locks are hidden for a more aesthetically pleasing look

#### LOAD LIMIT

- TimberLine FX Legs + JetStream FX Bar load limit 75 kg per pair (depending on vehicle fit and roof limit)



# System Adjustability

## Toe And Pitch

EASY ANGULAR ADJUSTMENTS FOR OPTIMUM AERODYNAMICS

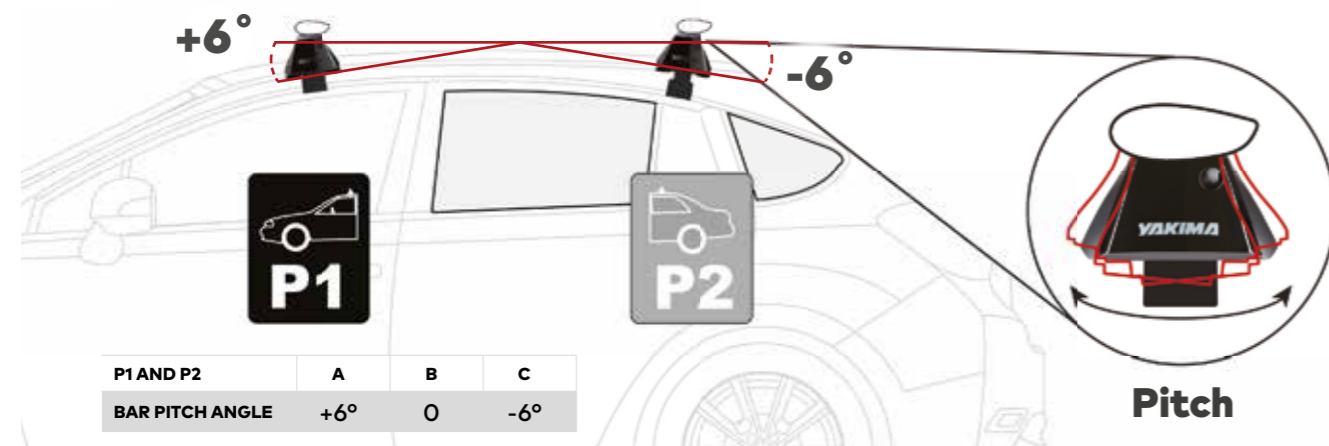

P1 AND P2	A	B	C
BAR PITCH ANGLE	+6°	0	-6°

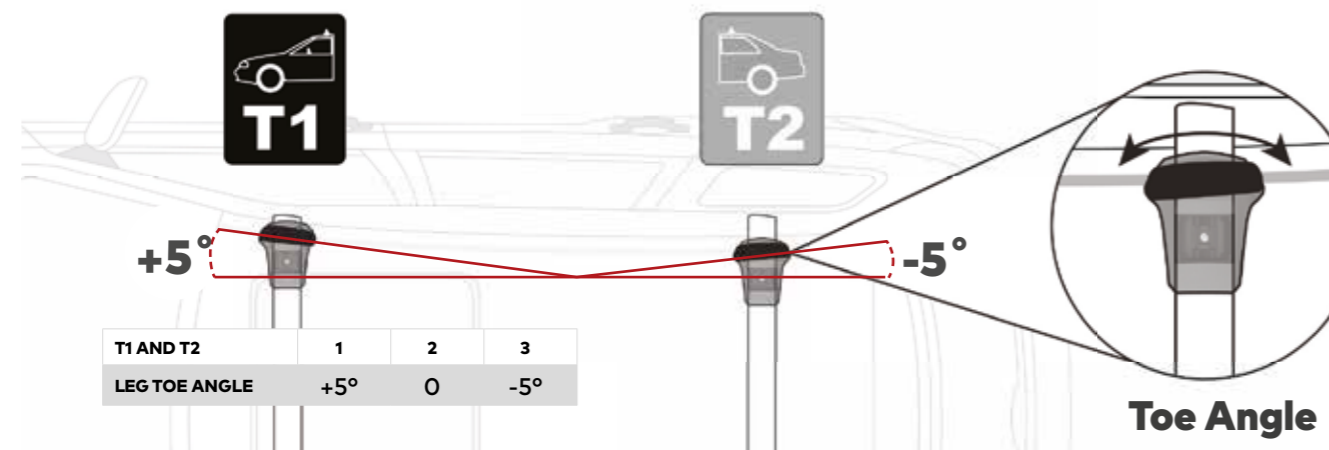

T1 AND T2	1	2	3
LEG TOE ANGLE	+5°	0	-5°

### FITTING NOTES

## Measurements

A SIMPLE MEASURING SYSTEM FOR PERFECT FITS

**M1** Front Crossbar  
Inner edge of driver's side leg to inner edge of passenger side leg.

**M2** Front Crossbar  
Corner of painted roof, or glass roof, to leading edge of front leg.

**M3** Rear Crossbar  
Inner edge of driver's side leg to inner edge of passenger's side leg.

**M4** Rear Crossbar  
Leading edge of front crossbar to leading edge of rear crossbar.

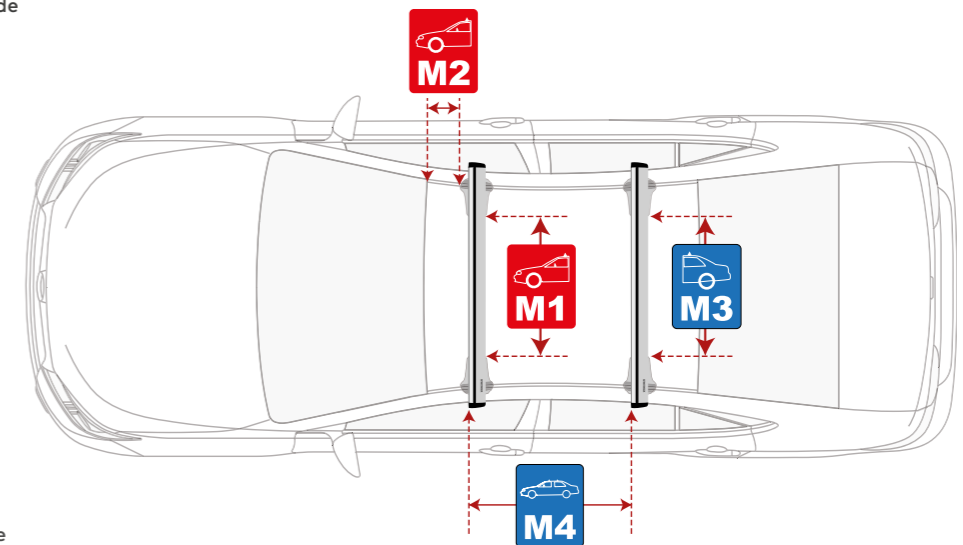

### FITTING NOTES



# Installation



## BaseLine Leg

1. Install lock cores
2. Open leg Cover
  - 2.5 Pull out security tab
3. Attach bar adapters to legs with Pitch Bolt
4. Remove underside infill
5. Slide legs onto bars
6. Scan QR Code to get measurements, settings, clip and pad details
7. Attach pads to legs
 

NB: start with front crossbars repeat process for rear
8. Adjust legs to M1 (front) & M3 (rear) measurements
9. Set bar Pitch angles P1 (front) & P2 (rear) and bar position with Pitch Bolt at full torque
10. Set Toe angle T1 (front) & T2 (rear) with Toe Bolt at full torque
11. For JetStream & TrimHD Bar: cut and install bar infill
12. Rear Crossbar set up – repeat above steps
13. Set legs on roof using M2 (front) & M4 (back) measurements
14. Install clips into legs
15. Use Swing Bolt and Drive Bolt to swing clips enough to make contact with roof (Fig2)
16. Evenly bring swing bolts to full torque by alternating sides while tightening. Do not move onto the drive bolts until swing bolts are fully torqued
17. Evenly bring drive bolts to full torque by alternating sides while tightening
18. Reinstall leg covers, lock with key and check install is secure

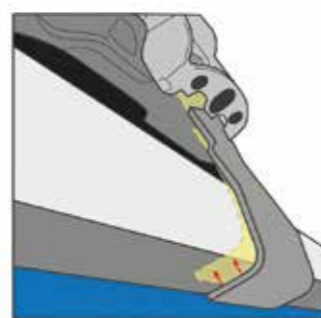
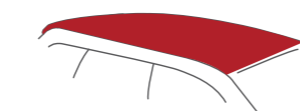
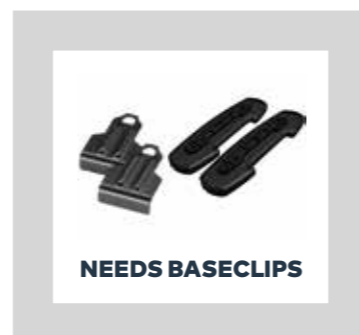

Fig2 - Ensure BaseClips make contact with door frame.



FOR NAKED ROOFS



## BaseLineFX Leg

1. Remove covers
2. Install lock cores
3. Turn Pitch Bolt 4-5 turns
4. Turn Toe Bolt 1 turn
5. Slide legs onto bars
6. Insert width retaining bolt and tighten 3.5 Nm
7. Scan QR Code to get measurements, settings, clip and pad details
8. Attach pads to legs
 

NB: start with front crossbars repeat process for rear
9. Adjust legs to M1 (front) & M3 (rear) measurements
10. Set bar Pitch angles P1 (front) & P2 (rear) and bar Position with Pitch Bolt at full torque (3.5 Nm)
11. Set Toe angle T1 (front) & T2 (rear) with Toe Bolt at full torque
12. For JetStream & TrimHD Bar: cut and install bar infill
13. Rear Crossbar set up – repeat above steps
14. Set legs on roof using M2 (front) & M4 (back) measurements
15. Install clips into legs
16. Use Swing Bolt and Drive Bolt to swing clips enough to make contact with roof (Fig2)
17. Evenly bring swing bolts to full torque by alternating sides while tightening. Do not move onto the drive bolts until swing bolts are fully torqued
18. Evenly bring drive bolts to full torque by alternating sides while tightening
19. Lock with key, reinstall leg covers and check install is secure

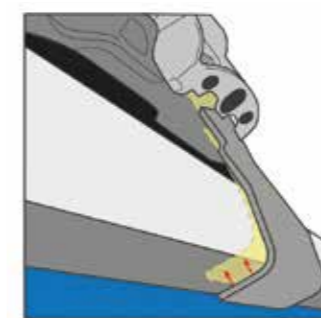
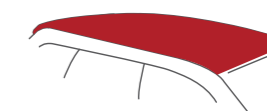
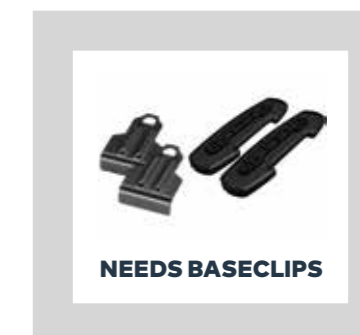

Fig2 - Ensure BaseClips make contact with door frame.



FOR NAKED ROOFS





## SkyLine Leg

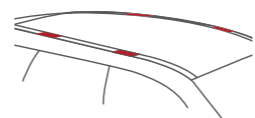

FOR FIXED POINT ROOFS

1. Scan QR Code to look up fit - Install SkyLine Landing pads on vehicle
2. Open leg cover
3. Install SKS Lock Cores into legs
4. Loosen Pitch Bolt 8-10 turns, then attach bar adapter to legs at full torque (3.5 Nm)
5. Remove underside infill
6. Adjust pitch bolt to ensure bar adapter sits slightly above leg
7. Slide legs onto underside of bars
8. Set legs into Landing Pads on roof evenly
9. Scan QR Code to look up Pitch settings
10. Set bar Pitch angle (P1 and P2) and bar Position with Pitch Bolt at full torque (3.5 Nm)
11. Before securing, remove bars from roof, cut and install bar infill
12. Return bars to roof and add bar end caps
13. Secure tower to Landing Pad by closing cover Door
14. Lock with key and check install is secure

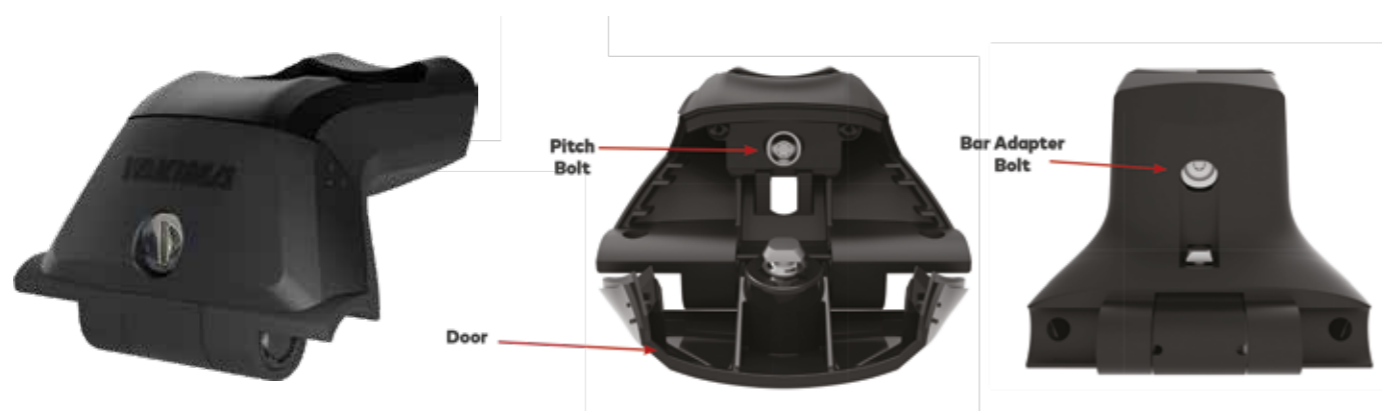

## SkyLineFX Leg

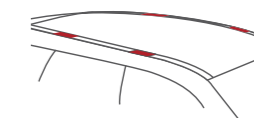

FOR FIXED POINT ROOFS

1. Install SkyLine Landing pads on vehicle first – Scan QR Code to look up fit
2. Remove leg cover and install SKS Lock Cores into legs
3. Flip internal casing/door down and loosen pitch bolt 4 turns
4. Close door and loosen width bolt 8 turns
5. Lift upper infill edge to allow SkyLine clip to be installed
6. Once clip installed resecure infill back in place
7. Insert legs onto bars
8. Scan QR code to look up pitch settings
9. Set bar pitch angle (P1 & P2)
10. Open leg covers and place bars on landing pads on vehicle, centreing bars
11. Tighten pitch bolt to 3.5 Nm
12. Tighten width bolt 3.5 Nm
13. Remove bars, measure, cut and insert under infill and add front and rear stickers
14. Place legs/bars back onto landing pads, close cover and lock
15. Reinstall leg covers and check install is secure







## SightLine Leg

1. Remove leg cover and add SKS Lock Core leaving in the unlocked position
2. Remove internal lock cover
3. Loosen clamp screw
4. Loosen security bolt then attach bar adapters to legs
5. Tighten bar adapter bolt 6-7 turns
6. Remove infill from underside of bars
7. Turn both legs and bars upside down and slide legs onto bars, check secure
8. Scan QR Code to get measurements, settings and clip details  
NB: start with front crossbars repeat process for rear. Sticker provided for Front and Rear Bar
9. Adjust legs to M1 (front) & M3 (rear) measurements
10. Set bar Pitch angles P1 (front) & P2 (rear) and bar Position with Pitch Bolt at full torque
11. Cut and install infill
12. Attach pads to legs
13. Attach end caps including securing bolt if required
14. Install clips into inner and outer clip carriers in legs
15. Set legs on roof rails, aligning pads with inner edges of rails with either M2 & M4 measurements or vehicles preset inboard side flush rail pinholes
16. Clamp clips to roof rail with Clamp Bolt at full torque (3.5 Nm)
17. Reinstall internal lock cover and use key to lock SKS core
18. Reinstall leg covers and check install is secure

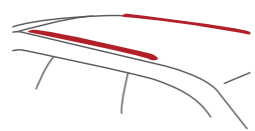

FOR FLUSH RAIL ROOFS

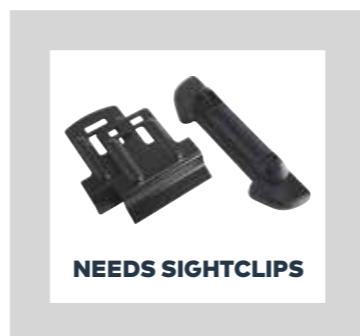

## SightLineFX Leg

1. Remove leg cover and add SKS Lock Core leaving in the unlocked position
2. Remove internal lock cover
3. Loosen Clamp screw 3 turns
4. Insert legs into bars
5. Insert width retaining bolt to full torque
6. Scan QR Code to get measurements, settings and clip details  
NB: start with front crossbars repeat process for rear. Sticker provided for Front and Rear Bar
7. Adjust legs to M1 (front) & M3 (rear) measurements
8. Set bar Pitch angles P1 (front) & P2 (rear)
9. Attach pads to legs
10. Install clips into inner and outer clip carriers in legs
11. Set legs on roof rails, aligning pads with inner edges of rails with either M2 & M4 measurements or vehicles preset inboard side flush rail pinholes
12. Clamp clips to roof rail with Clamp Bolt at full torque (3.5 Nm)
13. Reinstall internal lock cover and use key to lock SKS core
14. Reinstall leg covers and check install is secure

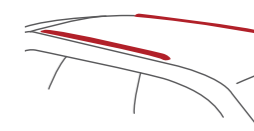

FOR FLUSH RAIL ROOFS





## TimberLine Leg

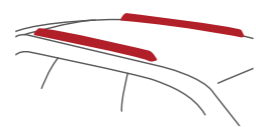

FOR RAISED RAIL ROOFS

1. Remove leg cover
2. Install lock cores
3. Loosen Bar Bed Bolt 8 turns
4. Attach bar adapters to legs
5. Loosen Strap Bolt approx. 100 times
6. Push Strap Bolt in, whilst push back of strap to loosen strap away from leg
7. Tighten bar adapter bolt 3.5 Nm
8. Remove underside infill from bars
9. Loosen Bar Bed Bolt approx. 5 turns
10. Turn bar and leg upside down and slide legs onto bars
11. Set legs on roof rails, aligning hash mark with centre of rails
12. Secure bar Position with Bar Bed Bolt at full torque (3.5 Nm)
13. Remove bars from roof, cut and install bar infill
  - 13.5 Return bars to roof
14. Cinch straps around rails with Strap Bolt at full torque (3.5 Nm)
15. Attach end caps
16. Reinstall leg covers, lock with key and check install is secure



## TimberLineFX Leg

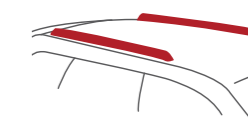

FOR RAISED RAIL ROOFS

1. Remove leg cover and locking cover
2. Loosen Bar width screw
3. Loosen clamp screw
4. Lift upper infill edge to allow clip to be installed
5. Once clip installed resecure infill back in place
6. Insert legs into bars
7. Attach bars to raised rails, centreing bars
8. Tighten Bar width screw 3.5 Nm
9. Tighten clamp screw 3.5 Nm
10. Cut and install underside bar infill
11. Insert cover and install lock cores
12. Lock with key, reinstall leg cover and check install is secure







# Accessories



CAMPING



CARGO



OFFROAD & TRADES



SNOW



FISHING & WATER



BIKE

## NOTES

Visit our website to find all your compatible accessories



AUSTRALIA



NEW ZEALAND



EU

### YAKIMA SUPPORT



Sample

yakimaglobal.com

Limited Lifetime Warranty AU & NZ.  
Limited 5 Year Warranty EU.

Yakima Australia Pty Ltd  
17 Hinkler Court  
Brendale, QLD 4500  
Australia

Tel: 1800 143 548  
[sales@yakima.com.au](mailto:sales@yakima.com.au)

Tel: 0800 477 672  
[sales@yakima.co.nz](mailto:sales@yakima.co.nz)

Tel: +61 7 3050 1200  
[sales@yakima.eu](mailto:sales@yakima.eu)

Yakima is a registered trademark of the Yakima Group of companies.

© Yakima Australia Pty Ltd. We (Yakima Australia Pty Ltd) own or licence the intellectual property rights in the trademarks featured in this publication (whether registered or unregistered) including without limitation: Yakima®, Hubco®, Whispbar®, QuickDock™, S-Wing®, SmartFoot™, SmartFill™, T-slot, the wing device, and the Whispbar shape. Products described in this publication may also be the subject of patent, design or copyright protection. All rights reserved.

---

**YAKIMA**®  
TAKE IT EASY.

   [yakima.com.au](http://yakima.com.au) | [yakima.co.nz](http://yakima.co.nz) | [yakima.eu](http://yakima.eu)