



**YAKIMA®**

**TAKE IT EASY™**

**Summer Sales Meeting  
6.1.23**





# Sp24 PRODUCT

---

THEME

# Strength from Within

## HEAVY DUTY PRODUCT

Yakima is achieving a new level of strength.  
45 years of experience, adapting to today's needs.  
Engineering from the start, to outlast & out perform.  
We stand behind it.

This is not an outward marketing ploy.  
This is really what who we are and what we do.  
This is strength from within.





# Heavy Duty Products

## CURRENT LINE

---



OverHaul HD  
OutPost HD  
HD Truck Accessories



HD Bar  
Track Tower  
LockNLoad Platform System  
Jeep RibCage



SkyRise HD  
RoadShower  
MajorShady 270



StageTwo

## 2024

---

New eBike Rack



In-Vehicle Storage System



Adventure Vehicle Roof Racks



HD Truck Accessories





# Strength for the Future

## BUILT FOR E-BIKES

There are so many new e-bike brands, every year.

Some are more traditional, following European designs and trends.

We have racks for those, and so do other rack brands.

But, many of them are new creatures.

No one has racks for those. We will.





# Strength from Within

## IN-VEHICLE GEAR STORAGE

Adventure vehicles are coming in all shapes and sizes.  
Vans...yes. Trucks...yes. SUV's...yes.  
Wagons and smaller CUV's...YES!

People want to outfit there vehicles to make their adventures easier, especially when it comes to organizing their gear.

People want to personalize it.





# Strength for Adventure

## ADVENTURE VEHICLE ROOF RACKS

Adventure vehicles are coming in all shapes and sizes.  
Van-life...yes. Trucks...yes. SUV's...yes.  
Subaru's and smaller CUV's...YES!

They want the look.  
They want it capable.  
They want to personalize it.





# Sp24 Collection

**STRENGTH FROM WITHIN**



**BIKE**

## OnRamp LX

Upgraded E-Bike Rack



*Strength for the Future*



**CARGO**

## MOD System

In-Vehicle Drawer System



*Strength from Within*



**ROOF RACK**

## RuggedLine HD

Adventure Vehicle Platform System



*Strength for Adventure*



# Sp24 PRODUCT

---

BIKE





# Strength for the Future

## BUILT FOR E-BIKES

There are so many new e-bike brands, every year.

Some are more traditional, following European designs and trends.

We have racks for those, and so do other rack brands.

But, many of them are new creatures.

No one has racks for those. We will.





# eBikes

## WEIGHT

Continues to evolve, many eBikes in Classes 1-3 bikes are between 40-65lbs, but new styles and trends show weights increasing beyond 65lbs.

## SHAPE

eBike Shapes continue to expand as the types of use, size of motors and batteries evolve. Designs are taking inspiration from standard bike, moto and open canvas futurism.

## POWER

- eBike Class 1: no throttle, max speed 20 mph
- eBike Class 2: throttle assisted, max speed 20 mph
- eBike Class 3: no throttle, max speed 28 mph
- Moped: max hp equivalent 50cc, max speed 30 mph
- Motorcycle: over hp equivalent 150cc

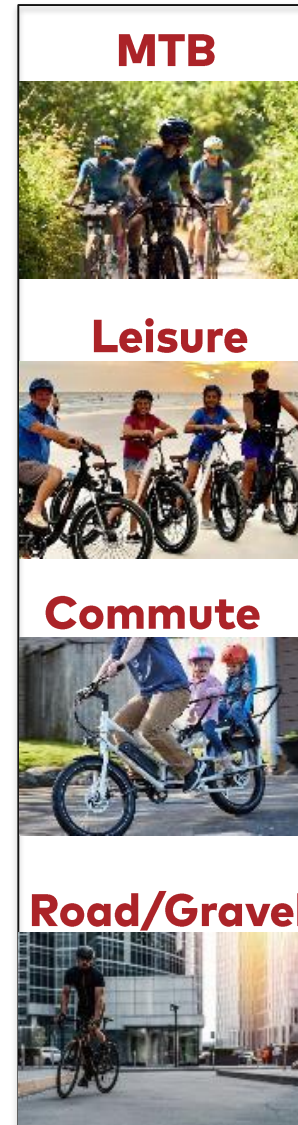

### MTB

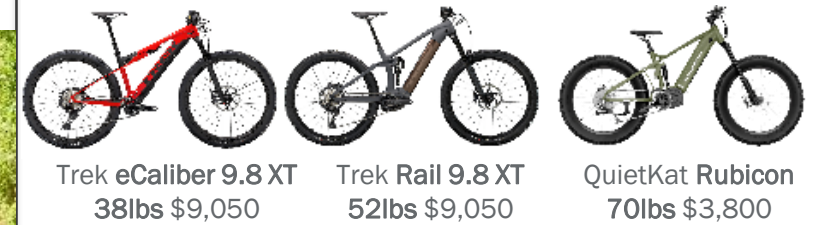

### Leisure

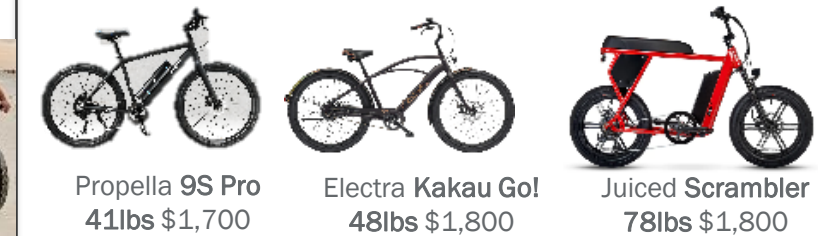

### Commute

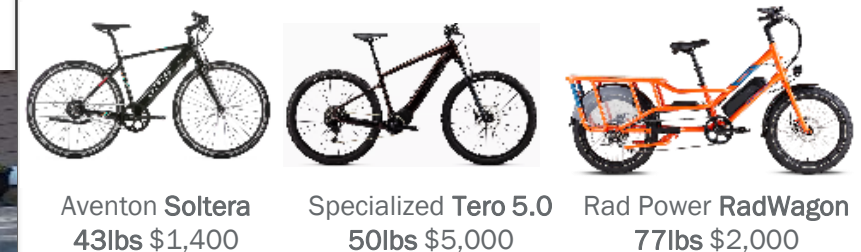

### Road/Gravel

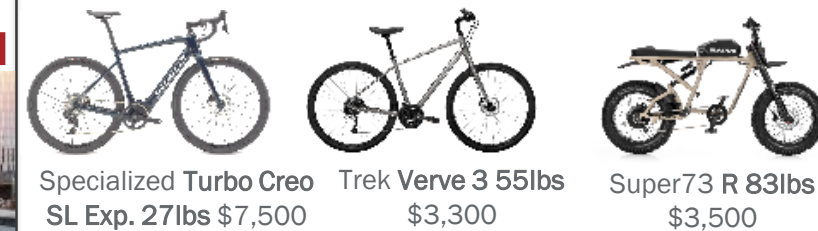

**Sub 45lbs**

**45-65lbs**

**65-85lbs**

# Target Personas



## Urban Athlete

**ATHLETIC, COMPETITIVE,  
BUSTLING/ABSORBED LIFE**

The Urban Athlete is a passionate rider, a part of their life they enjoy and invest money into. With many in urban environments, they have a less traditional definition of cycling – just as inclusive of park paths and busy roads as mountains and forests. They have significant barriers to increasing engagement – feeling tight on time, being far from outdoor places or open roads, preferring indoor comforts. Many grew up in team sports and are very active and competitive. They are highly style conscious, often favoring athletic wear, and bringing this apparel in their cycling.



## Aspirational Core

**PERFORMANCE SEEKING,  
ASPIRATIONAL, INTERMITTENT**

The Aspirational Core looks up to high performance riders, inclined to ride for fitness and fun. Some of the fun may not be realistic in their everyday life, but it may warrant an occasional special weekend away bike trip to a destination location. Rather than participating in a large range of activities, they focus on improving their performance in a specific cycling discipline. They do feel they need good gear but are open to relying on rentals or a friend's bikes on weekend or annual trips. They favor athletic fashion and fashion brands slightly more than traditional bike clothing brands.



## Athleisurist

**LOW INTENSITY, ENJOYMENT,  
EMOTIONALLY DRIVEN**

The Athleisurist is comfortable with where they are right now. They tend to be a bit older, a little less social and value experiences highly. This is reflected in how they engage with cycling. They find their 'center' in the outdoors. Though they aren't extremely active while cycling, they are in good health and have few barriers to getting outside. Their aspirations are more in line with leisure than intensity. For gear, they tend to stick to the basics – seeking versatility, function, and comfort. They look to long-standing brands, sensible brands to equip them.

## Secondary



## Outdoor Native

**ESTABLISHED, HIGHLY INVOLVED,  
ADVENTURE DRIVEN**



## Achiever

**PERFORMANCE DRIVEN,  
ALWAYS RIDING, FULLY ENGAGED**



# Target Personas



## Urban Athlete

ATHLETIC, COMPETITIVE,  
BUSTLING/ABSORBED LIFE

### DEMOGRAPHICS

- 20% of consumers & 33% of outdoor market spend,
- 61% between 18-34, 39% F / 61% M, 60% With Kids in the House, 33%, Higher Income
- 23% Hispanic, 8% Asian
- Live in City Center

### GEAR NEEDS

Technical, stylish and specific-use gear. They like versatile and proven industry brands that are well known and long standing. Tend to feel unspoken to by these brands marketing messages



## Aspirational Core

PERFORMANCE SEEKING,  
ASPIRATIONAL, INTERMITTENT

### DEMOGRAPHICS

- 14% of consumers & 14% of outdoor market spend.
- 51% between 18-34, 43% F / 57% M, 45% With Kids in the House
- 59% Caucasian, 8% Asian
- No locationality skew.

### GEAR NEEDS

Quality specific-use gear, but not top end. They like brands that are used by friends or family and long standing in industry. They shop at sporting good chains and specialty chains.



## Athleisurist

LOW INTENSITY, ENJOYMENT,  
EMOTIONALLY DRIVEN

### DEMOGRAPHICS

- 20% of consumers & 12% of outdoor market spend,
- 60% between 45-65, 59% F / 41% M, 34% With Kids in the House
- 75% Caucasian
- Lives in small town or rural areas.

### GEAR NEEDS

Comfortable, and versatile use gear. Less concerned with style or the opinions of others. They shop at Sporting Goods Chains and Mass Stores, but will rent or demo equipment as well.

## Secondary



## Outdoor Native

ESTABLISHED, HIGHLY INVOLVED,  
ADVENTURE DRIVEN



## Achiever

PERFORMANCE DRIVEN,  
ALWAYS RIDING, FULLY ENGAGED



2024

# OnRamp LX

The OnRamp LX blends sleek design with the strength and versatility modern ebikes demand to create a no-compromise rack to ease the challenge of carrying not only heavier and longer bikes, but bikes with fenders. This is the solution many have been waiting for.





BIKE



Inside Scoop Video link

<https://showroom.yakima.com/Video/Watch?videoid=891>



# Versatile Bike Fit







BIKE



80lbs Bikes



34"-54" Trays





**Fat Tires**



**Fat Frames**





**Wide Ramp**



**Fender Fit**





BIKE

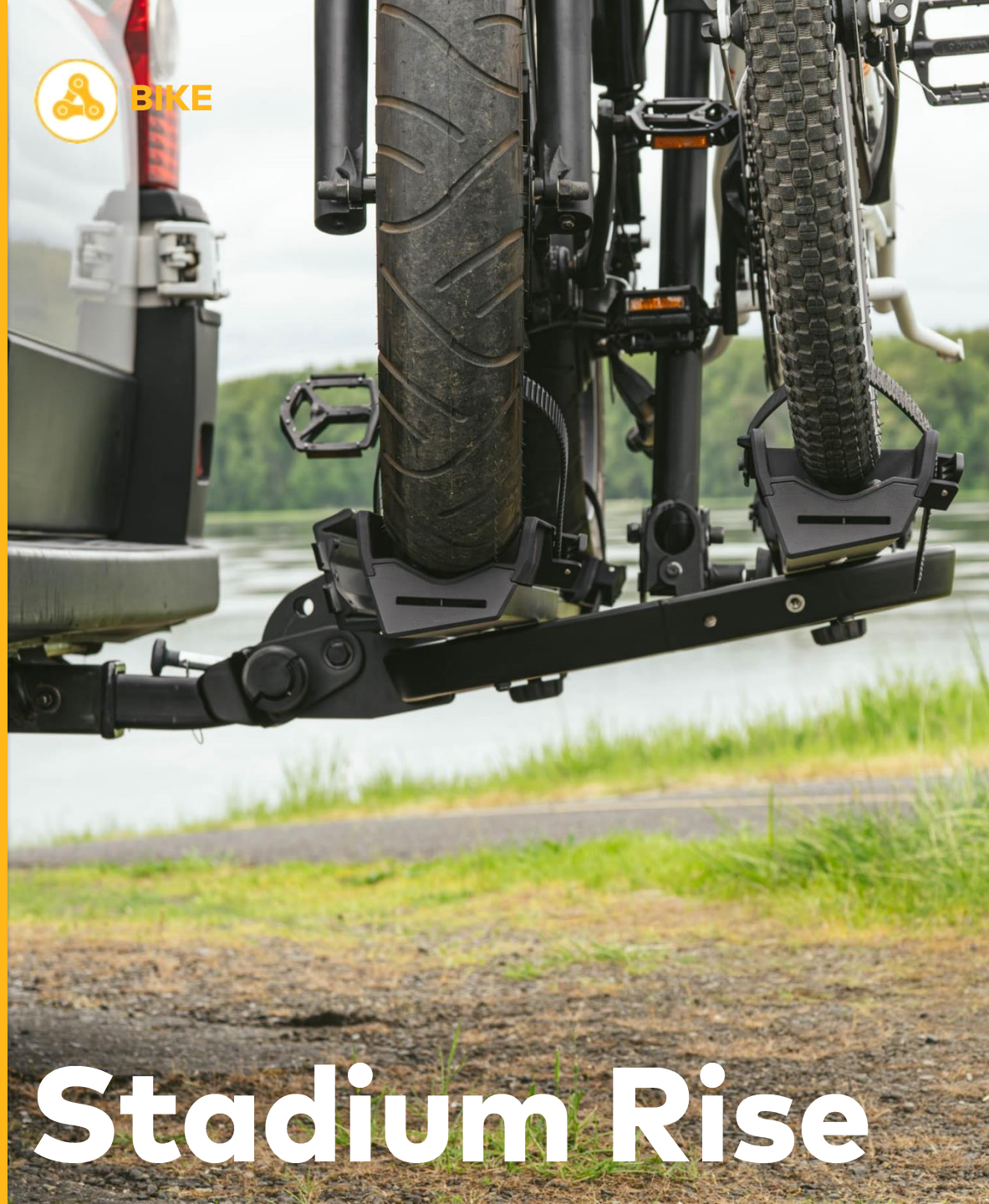

**Stadium Rise**

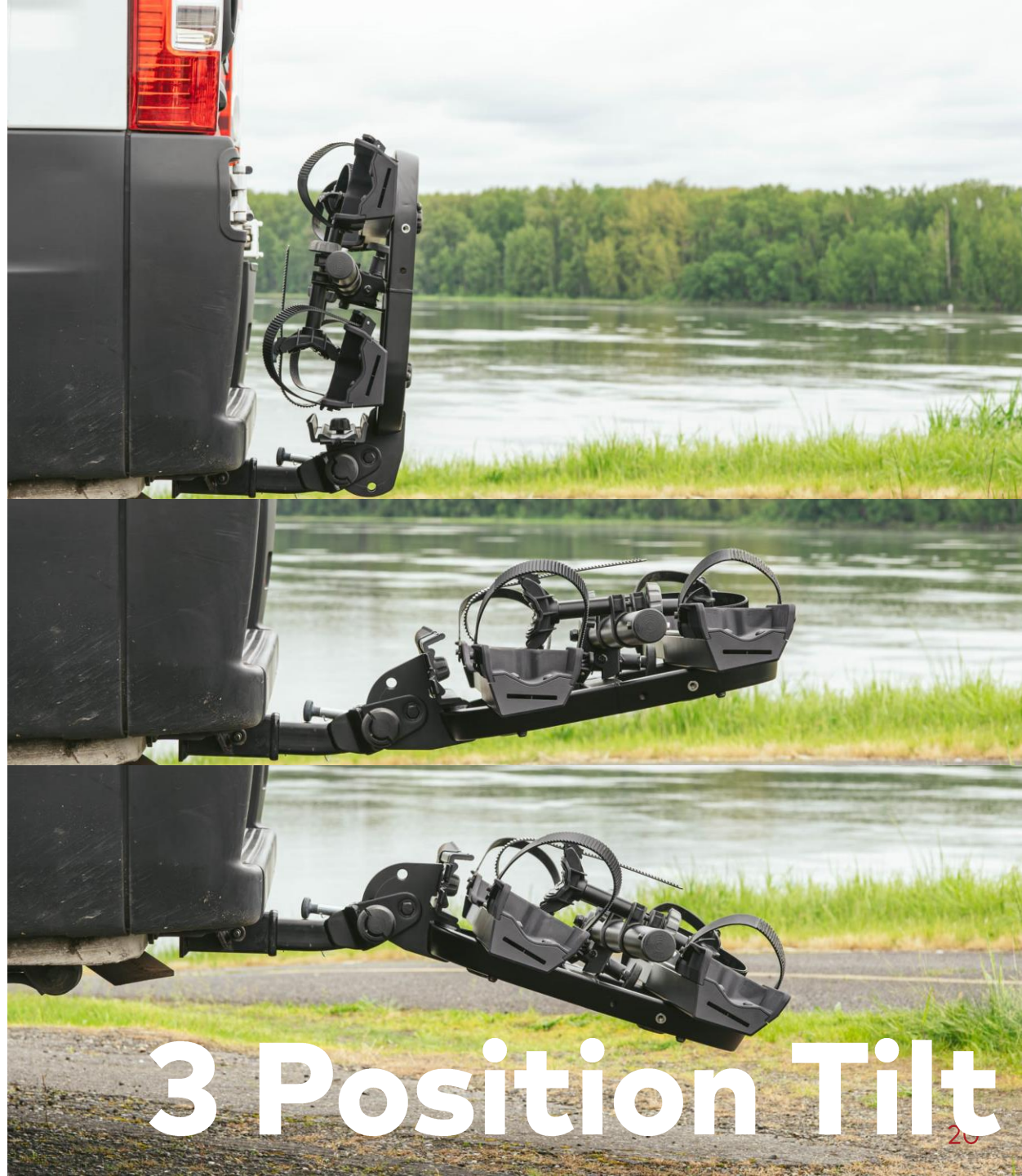

**3 Position Tilt**





**Stadium Rise**



**3 Position Tilt**





**Easy to Use**



**Full RV Rating**





Oregon

YAKIMA

EXO LitKit



BackSwing



**YAKIMA**

**SARIS**

**THULE**

**THULE**

**YAKIMA**

**HR HOLLYWOOD RACKS**



Brand	Yakima	Saris	Thule	Thule	Yakima	Hollywood
Style	<b>NEW OnRamp LX</b>	<b>Door County</b>	<b>2023 Epos</b>	<b>EasyFold XT</b>	<b>CURRENT OnRamp</b>	<b>Destination E</b>
MSRP	<b>\$999 2 bike</b>	<b>\$1,300 2 bike</b>	<b>\$1,000 2 bike \$1,100 3 bike \$1,250 2 bike w/lights</b>	<b>\$1,000 2 bike</b>	<b>\$749 2 bike</b>	<b>\$700 2 bike</b>
Max Bike Weight	<b>80lbs/36.3kg</b> ★	60lbs/27.2kg	66lbs/30kg	65lbs/29.4kg	66lbs/30kg	70lbs/31.8kg
Max Bike Wheelbase	<b>54"/137cm</b> ★	48"/122cm	53"/135cm	51"/130cm	50"/127cm	50"/127cm
Max Tire Size	<b>5"</b> ★	3" (4.5" Fat Kit)	3" (4.7" Fat Kit)	3" (4.7" Fat Kit)	3.25" (4.5" Fat Kit)	4.5"
Wheel Size	<b>Up to 29"</b> ★	20-29"	16-29"	20-29"	Up to 29"	20-29"
RV Rating	<b>Yes, 100%</b> ★	No	No	No	Yes, 100%	Yes, 100%
Special Features & Accessories	Included Ramp/ <b>Exo LitKit, BackSwing &amp; StraightShot Compatible</b>	Electric Up-Down / Folds & Rolls	Included Ramp/ Folds & Rolls/ 2 Bike w/Lights	Included Ramp/ Folds & Rolls	Included Ramp	Included Ramp
Tilt Up/Down	Three Position	Two Position, Remote	Two Position, Remote	Two Position, Remote	Four Position	Three Position, Remote
Fender Compatible	Yes	Yes	Yes	Yes	Yes	Yes
Hitch Offering	2" & 1.25"	2" only	2" & 1.25" (adaptor?)	2"/1.25" adaptor	2" & 1.25"	2" only
Bike & Hitch Locks Included	Hitch Only	Yes	Yes	Yes	Yes	Yes
Rack Weight	53lbs/24kg	63lbs/28.6kg	38lbs/17.2kg	45lbs/20.4kg	43lbs/19.5kg	46lbs/20.9kg
Folded Rack Dimensions	40-60x25x7.5" 102-152x63x19cm	NA, Similar to EasyFold	27x11x29" (2 bike) 69x27x73cm (2 bike)	31x15x26" 79x38x66cm	52-56x24x9" 132-142x61x22cm	56x39x9" 143x100x22cm

\*reflects 2023 pricing



### Frame Strap Bike Racks



Style	<b>NEW OnRamp LX</b>	<b>CURRENT OnRamp</b>
<b>MSRP</b>	<b>\$999 2 bike</b>	<b>\$699 2 bike</b>
<b>Max Bike Weight</b>	<b>80lbs/36.3kg ★</b>	66lbs/30kg
<b>Max Bike Wheelbase</b>	<b>54"/137cm ★</b>	50"/127cm
<b>Max Tire Size</b>	<b>5" ★</b>	3.25" (4.5" Fat Kit)
<b>Wheel Size</b>	<b>Up to 29" ★</b>	Up to 29"
<b>RV Rating</b>	<b>Yes ★</b>	Yes
<b>Special Features &amp; Accessories</b>	Included Ramp/ <b>Exo LitKit, BackSwing &amp; StraightShot Compatible</b>	Included Ramp
<b>Tilt Up/Down</b>	Three Position	Four Position
<b>Fender Compatible</b>	Yes	Yes
<b>Hitch Offering</b>	2" & 1.25"	2" & 1.25"
<b>Bike &amp; Hitch Locks Included</b>	Hitch Only	Yes
<b>Rack Weight</b>	53lbs/24kg	43lbs/19.5kg

### Wheel Hook Bike Racks



StageTwo	HoldUp Evo	HoldUp
<b>\$749 2 bike \$599 +2 bike</b>	<b>\$599 2 bike \$449 +2 bike</b>	<b>\$549 2 bike \$399 +2 bike</b>
70lbs/31.8kg	50lbs/22.7kg	60lbs/27.2kg
52"/132cm	48"/122cm	48"/122cm
3.25" (5" Fat Kit)	4.8"	2.5"-3.0"
20-29"	20-29"	20-29"
Yes (2" 2 bike only)	No	No
Ramp & SafetyMate Compatible	??	??
Three Position, Remote	Three Position	Three Position
No	No	No
2" & 1.25"	2" & 1.25"	2" & 1.25"
Yes	Yes	Yes
66lbs/30kg	50.7lbs/23kg	49lbs/22.2kg

\*reflects 2023 pricing



2024

# OnRamp LX

## KEY STRENGTHS

- Secures Modern Ebikes Of All Types
- Designed With Bike Ramp In Mind
- Intuitive To Use For All Users

## KEY UPDATES

- Longer Trays For Long Wheelbase Bikes
- Wider Tray & Ramp For All Tire Sizes
- Heavier Bikes, 2" - 80lb Per Bike & 1.25" - 70lb Per Bike
- RV, BackSwing, StraightShot, Exo LitKit Approved
- Easier To Use, Load, Unload and Store

PRODUCT	PART #	NEW / TRANSITION	MSRP
OnRamp LX 2"	8002756	NEW	\$ 999
OnRamp LX 1.25"	8002757	NEW	\$ 999

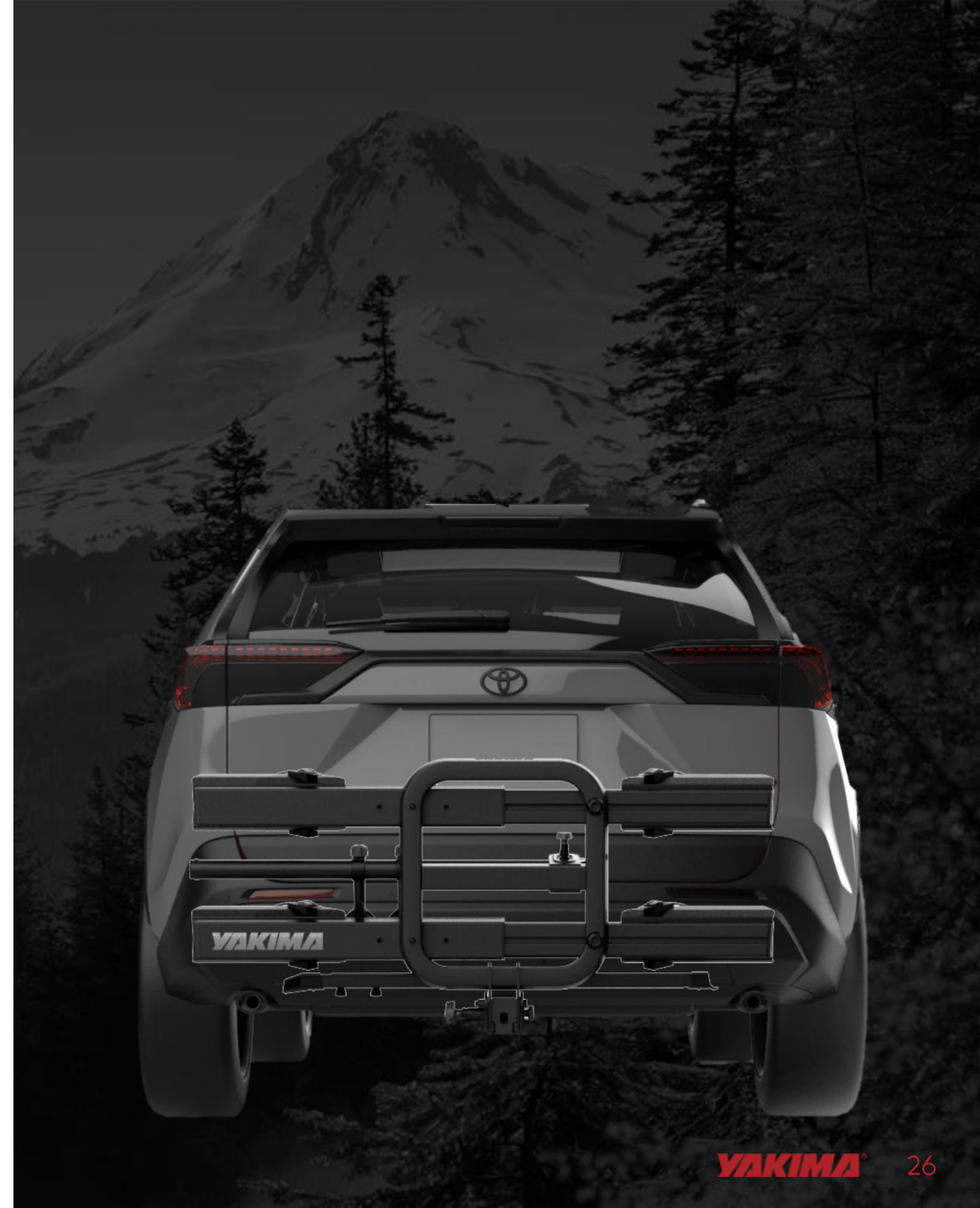





BIKE

# 2024

# OnRamp LX

## LAUNCH PLAN

- June 15, 2024 ATS...
- Current OnRamp Remains Inline
- Current Market Conditions
  - Overstock of Competitors & Yakima Racks
  - Pricing Changes, Up and Down
  - Post COVID Retail Norms in Buying Behavior
- Target Broad Channel Range
  - Independent Bike and eBike Dealers
  - Mass Sport/Outdoor Specialty
  - Auto/Rack Specialty, Etc.
  - New Mass & Specialty Dealers to Bike via eBikes

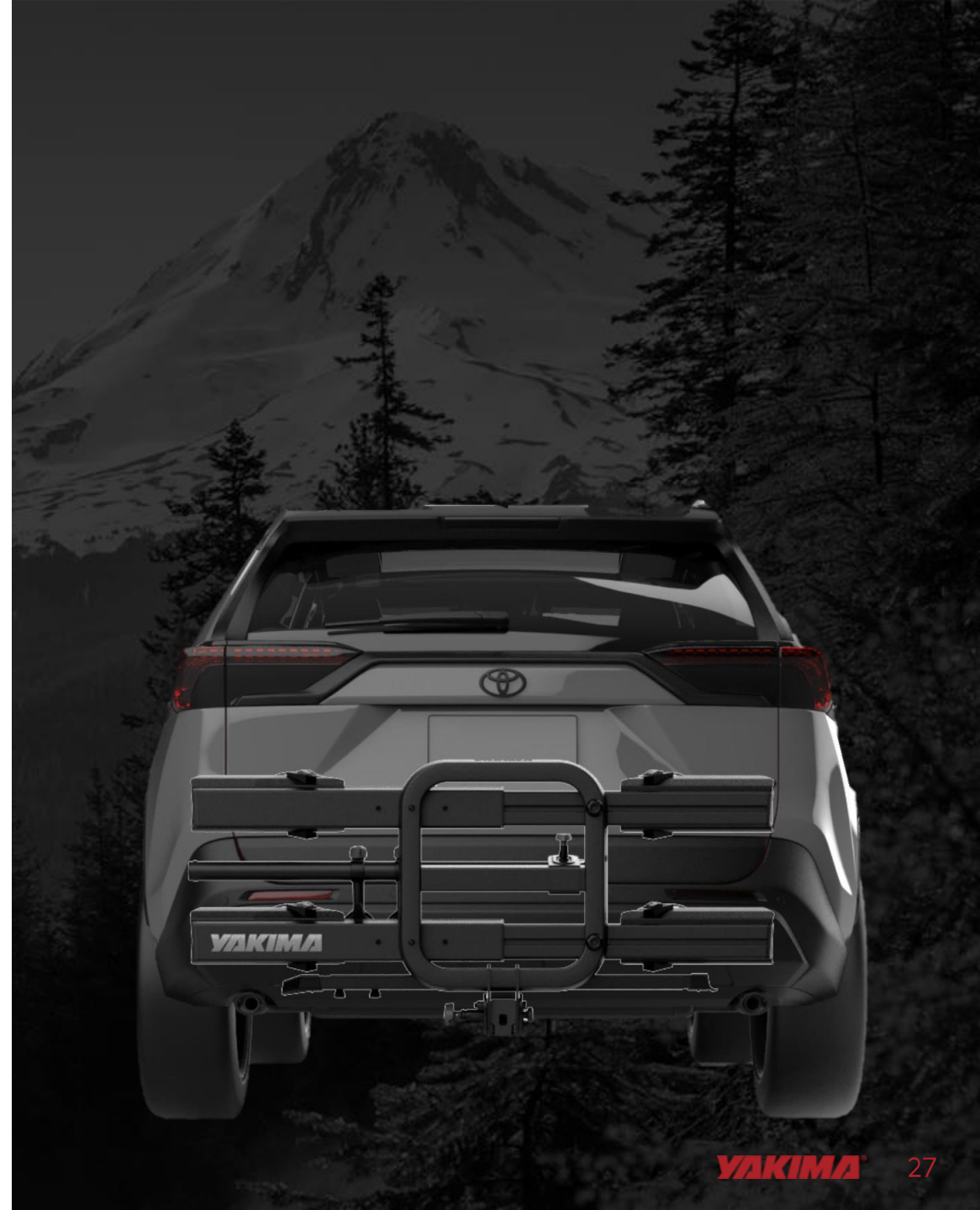



2024

# HighRoad & HighSpeed

Secure, sleek, and simple to use, Yakima's premium rooftop bike racks are the market choice. Bikes are secured using the easy-to-use TorqueRight™ knob for a precise and strong hold. The low-profile design minimizes hatch interference with near universal fit to most roof racks.





**BIKE**

**2024**

# HighRoad & HighSpeed

## KEY UPDATES

- Longer Trays For Longer Wheelbase Bikes
  - HighRoad – 52.25" New Max Wheelbase
  - HighSpeed – 50" New Max Wheelbase
- Longer 40" Crossbar Fit (M4) For Modern Vehicles
- Color Update To Silver Accents
- No Additional Changes To Parts, Fit Or Capacity





BIKE

2024

# HighRoad & HighSpeed

## KEY STRENGTHS

- Top Roof Rack Brand In NPD Market
  - Yakima Roof Racks #1, \$4.3m 46% Share
- Top Roof Rack In NPD Market
  - #1 Yakima HighRoad \$1.9m
  - #2 Thule UpRide \$1.4m
  - #3 Yakima FrontLoader \$1.3m
- Low Profile, High Quality Design
- TorqueRight's Easy & Secure Fit



PRODUCT	PART #	NEW / TRANSITION	MSRP
HighRoad	8002139	TRANSITION	\$ 299
HighSpeed	8002140	TRANSITION	\$ 289





# Sp24 PRODUCT

---

IN-VEHICLE CARGO

# Strength from Within

## IN-VEHICLE GEAR STORAGE

Adventure vehicles are coming in all shapes and sizes.  
Vans...yes. Trucks...yes. SUV's...yes.  
Wagons and smaller CUV's...YES!

People want to outfit there vehicles to make their adventures easier, especially when it comes to organizing their gear.

People want to personalize it.





# Adventure Vehicles

In-Vehicle Storage solutions are prevalent in the Overlanding space with quite a few options.

Companies like Goose Gear and ARB (Outback Solutions) have been serving this market for years.

Competitive in-vehicle drawer systems are very expensive, quite heavy & vehicle specific. These systems are quite elaborate, require the user to highly modify the vehicle in most instances.



# For Everyone

Yakima set out to solve these problems and make a system that is more universal, lighter weight and less expensive while still capturing the basic essence of what competitive drawer systems provide, maybe with an adventure vehicle "light" feel?

We have seen other overlanding companies and products start to show up in retailers like REI (most stores have a full Dometic fridge display for example).

The idea is to bring In-Vehicle Storage solutions to the masses with a more universal system that is less expensive, lighter and more Yakima.





# Yakima MOD Drawer System

MODULAR IN-VEHICLE STORAGE SYSTEM





Inside Scoop Video link

<https://showroom.yakima.com/Video/Watch?videoid=893>





CARGO

# Yakima MOD System

## IN-VEHICLE STORAGE SYSTEM

- Rear cargo area gear storage & organization
- “Universal” attachment strategy to any vehicle with rear cargo tie-down points
- Target most popular vehicles first, with real fits, but also provide guidance for others
- Full system of drawers and accessories
- Completely configurable



# Yakima MOD System: HomeBase

## IN-VEHICLE STORAGE SYSTEM

- MOD HomeBase is base unit for MOD System
  - "Universal" attachment strategy
  - 3 sizes for different vehicles and needs
  - Lockable single drawer w/included bamboo divider
  - 100 lb drawer rating / 250 lb payload rating
- 
- MSRP \$999 / \$1199 / \$1399





# Yakima MOD System: Topper

## IN-VEHICLE STORAGE SYSTEM

- MOD Toppers come in 3 sizes to match HomeBase
  - Attach to HomeBase with 4 spring loaded bolts
  - Utilize Yakima torque tool that comes with towers
  - 50 lb drawer rating
  - 2 inches taller than HomeBase for different gear fit
- 
- MSRP \$699 / \$849 / \$999



# Yakima MOD System: GearCrate

## IN-VEHICLE STORAGE SYSTEM

- GearCrate is a premium tote with structure for MOD System
- Includes thermoformed lid and moveable divider
- Quick attach goes on & off MOD system super fast
- Technical tote loaded with details (handles, loops, pulls, built-in stretch net)
- 2 Sizes
- MSRP \$169 / \$199





# Yakima MOD System: GearTote

## IN-VEHICLE STORAGE SYSTEM

- GearTote is basic tote for MOD System
- Very similar in feel and structure to EXO GearTotes
- Quick attach goes on & off MOD system super fast
- Includes removeable divider and is collapsible for storage
- 2 Sizes
- MSRP \$79 / \$99



# Yakima MOD System: MicroTotes

## IN-VEHICLE STORAGE SYSTEM

- MicroTotes is a set of 6 totes
- Perfectly fit ½ of HomeBase M
- 3 large & 3 small removeable totes
- Also works on other sizes of HomeBase (move the divider)
- Great add on sale
- MSRP \$79

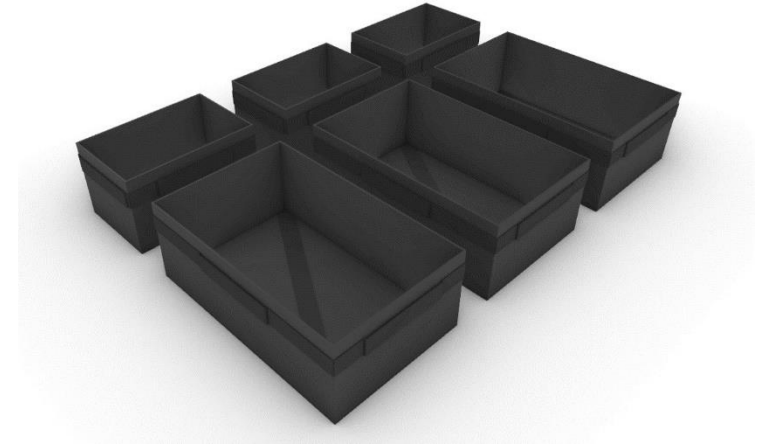





CARGO

# Yakima MOD System: Accessories

## IN-VEHICLE STORAGE SYSTEM

- MOD Work Space is a drop in table top (2 Sizes)
  - MOD Stretch Net (1 Size)
  - MOD Fridge Slide Mounting Kit (for Dometic Slides)
  - Great add on sale
- 
- MSRP Work Space \$129 / \$179
  - MSRP Stretch Net / Fridge Slide Kit \$59 / \$99

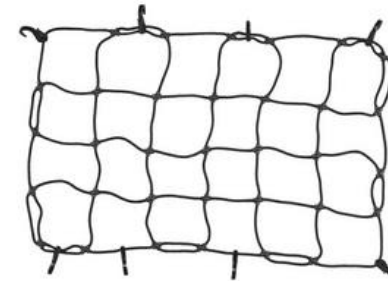



# Yakima MOD System: Accessories

## IN-VEHICLE STORAGE SYSTEM

- MOD FIT Specific Accessories
- MOD Riser Kit
- MOD Fit Kit 1 (specific vehicles)
  
- MSRP Riser \$99
- MSRP Fit Kit \$29





# Yakima MOD System Pricing



Product	Price w/crates	Price w/totes
HomeBase M	\$999	\$999
GearCrate / Tote M	\$169	\$79
GearCrate / Tote M	\$169	\$79
Total	<b>\$1337</b>	<b>\$1157</b>

Product	Price
HomeBase L	\$1199
Topper L	\$849
Topper L	\$849
Total	<b>\$2897</b>

# Competition vs. Yakima MOD System



## Goose Gear Module + Mounting Plate \$2090

- Vehicle specific
- Permanent vehicle modification
- Product weight 123.4 lb
- Recommend no more than 100 lb per drawer



## Yakima MOD System HomeBase L **\$1199**

- Universal fit
- No permanent vehicle modification
- Product weight approx. 50 lb
- Tested to 100 lb per drawer



# Competition vs. Yakima MOD System



## ARB Outback Solutions \$2505

- Vehicle specific
- Permanent vehicle modification
- Product weight 120 lb
- 330 lb per drawer



## Yakima MOD HomeBase L + Fridge Slide Kit **\$1698**

- Universal fit
- No permanent vehicle modification
- Product weight approx. 70 lb
- Tested to 100 lb per drawer / 250 lb top surface

# Competition vs. Yakima MOD System



## ARB Outback Solutions \$3688

- Vehicle specific
- Permanent vehicle modification
- Product weight 240 lb
- 330 lb per drawer



## Yakima MOD HomeBase L + 2 Topper L **\$2897**

- Universal fit
- No permanent vehicle modification
- Quick on & off – 4 bolts
- Product weight approx. 120 lb
- Tested to 100 lb per drawer / 50 lb Topper





# Competition vs. Yakima MOD System



## Front Runner SUV Drawers Med + 4 Wolf Pack Pro Plastic Totes \$1995

- Starting to offer "universal" options
- Less permanent vehicle modification
- Product weight 125 lb
- 250 lb per drawer



## Yakima MOD HomeBase L + 2 GearCrate L [\\$1597](#)

- Universal fit
- No permanent vehicle modification
- Quick attach in seconds
- Product weight approx. 70 lb
- Tested to 100 lb per drawer / 40 lb GearCrate

## In-Store Display / Samples

- Quality Samples Coming Soon: Sept / Oct
- In-Store Merchandising Concepts
  - Small Footprint
  - Paired with Lifestyle Popup or Poster





# Yakima MOD System

## IN-VEHICLE STORAGE SYSTEM

NEW



**MOD HomeBase MD**  
#8007465

NEW



**MOD HomeBase LG**  
#8007466

NEW



**MOD HomeBase XL**  
#8007467

NEW



**MOD Topper MD**  
#8007468

NEW

**MOD Fridge Side Mounting Kit**  
#8007476

NEW

**MOD Fit Kit 1**  
#8007472

NEW

**MOD Stretch Net**  
#8007477

NEW

**MOD Riser Kit**  
#8007472

NEW



**MOD Topper LG**  
#8007469

NEW



**MOD Topper XL**  
#8007470

NEW



**MOD Work Space**  
MD/LG #8007474, XL #8007475

NEW



**MOD GearCrate MD**  
#8007478

NEW



**MOD GearCrate LG/XL**  
#8007479

NEW



**MOD GearTote MD**  
#8007480

NEW



**MOD GearTote LG/XL**  
#8007481

NEW



**MOD MicroTotes**  
#8007498

# Sp24 Product List

## TRANSITION/LINE PLANNER



CATEGORY	PRODUCT	NEW / TRANSITION	MSRP
CARGO	MOD HomeBase MD	NEW	\$ 999
CARGO	MOD HomeBase LG	NEW	\$ 1,199
CARGO	MOD HomeBase XL	NEW	\$ 1,399
CARGO	MOD Topper MD	NEW	\$ 699
CARGO	MOD Topper LG	NEW	\$ 849
CARGO	MOD Topper XL	NEW	\$ 999
CARGO	MOD Riser Kit	NEW	\$ 99
CARGO	MOD Fit Kit 1	NEW	\$ 29
CARGO	MOD Work Space MD/LG	NEW	\$ 129
CARGO	MOD Work Space XL	NEW	\$ 179
CARGO	MOD Fridge Slide Mounting Kit	NEW	\$ 99
CARGO	MOD Stretch Net	NEW	\$ 59
CARGO	MOD GearCrate MD	NEW	\$ 169
CARGO	MOD GearCrate LG/XL	NEW	\$ 199
CARGO	MOD GearTote MD	NEW	\$ 79
CARGO	MOD GearTote LG/XL	NEW	\$ 99
CARGO	MOD MicroTotes	NEW	\$ 79





# Why Yakima & How We Win?

- Bringing it to a broader audience
  - Outdoor Consumers & General Travel
- Easy shopping experience
  - Clear options & vehicle compatibility
- Lower price
- Approachable install & use
  - Non-custom install (no drilling)
  - "Universal" fit in vehicles
  - No permanent modification to vehicle
  - Transferrable to a new vehicle





A dark, atmospheric photograph of a dense evergreen forest. The trees are silhouetted against a misty, grey background, creating a sense of depth and mystery. The lighting is low, emphasizing the textures of the needles and the verticality of the trunks.

# Sp24 PRODUCT

---

**ADVENTURE VEHICLE ROOF RACKS**



# Strength for Adventure

## ADVENTURE VEHICLE ROOF RACKS

Adventure vehicles are coming in all shapes and sizes.  
Van-life...yes. Trucks...yes. SUV's...yes.  
Subaru's and smaller CUV's...YES!

They want the look.  
They want it capable.  
They want to personalize it.



# Background



Platform style roof racks are popular for adventure vehicles large and small, hardcore and aspirational. What do people want for a vehicle connection style?

Low profile continuous rail  
Off-road capable

High weight capacity  
Integrated Fairing

We have been repeatedly asked by our consumers, dealers and Reps for a version of this attachment type if we want to increase our success with the LockNLoad Platform product line.





ROOF RACK

## Background - Competition



Pioneer Platform w/ Backbone

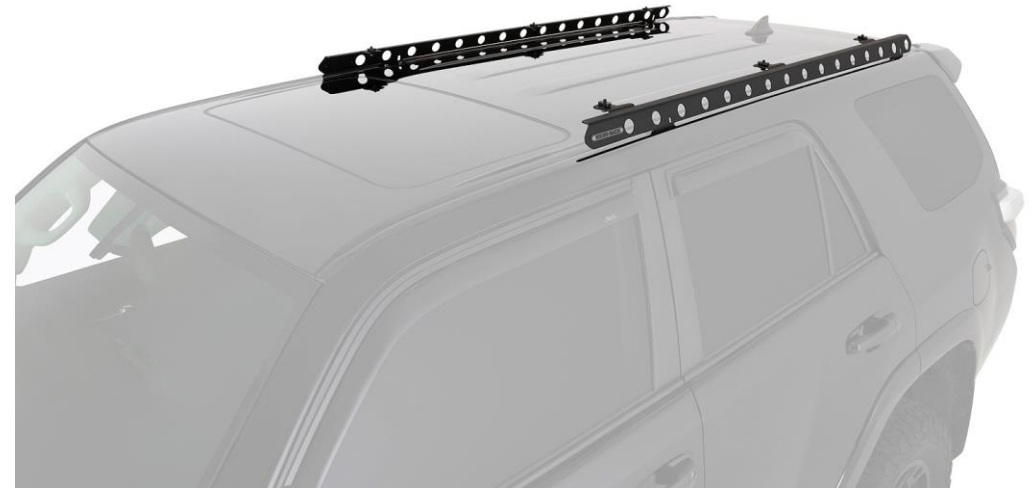



Front Runner – Tacoma fit



Background - Competition



Front Runner – RAM fit





## Background - Competition



Original Rack – Tacoma fit



Original Rack - RAM fit



# YAKIMA RUGGEDLINE HD







Inside Scoop Video link  
<https://showroom.yakima.com/Video/Watch?videoId=889>



## ROOF RACK

# RuggedLine HD

## LOCKNLOAD SYSTEM

- Platform-to-Vehicle Mounting System
- Designed for high capacity & off-road use
  - ✓ 220-330 lb. load ratings (100% off-road)
- Steel spines attach to fixed points
- Custom designed for each vehicle
- Custom metal fairing for noise & style



**2019+ RAV4**





# ROOF RACK

## RuggedLine HD LOCKNLOAD SYSTEM

- Range of Vehicle Types
- 6 SKU's
- 5 vehicles + 1 track fit



Toyota 4Runner  
5th Gen



Toyota Tacoma  
2nd & 3rd Gen Double Cab



Jeep Wrangler/RibCage

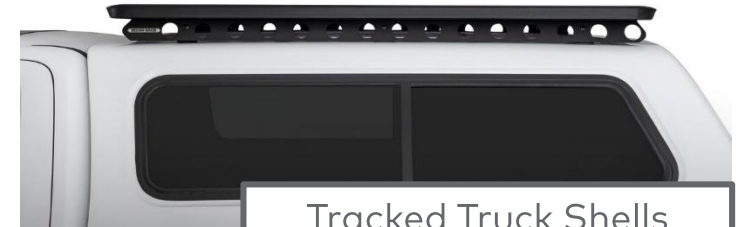

Tracked Truck Shells

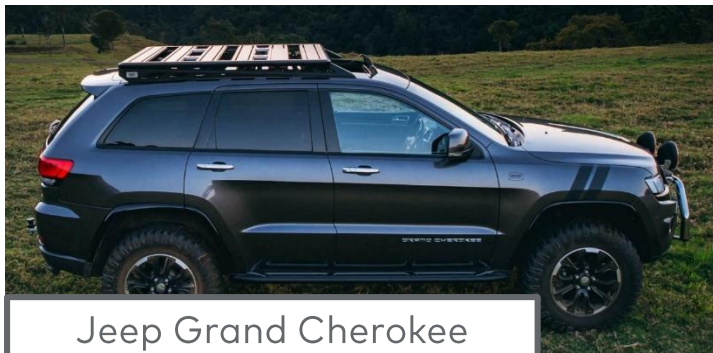

Jeep Grand Cherokee  
4th Gen



RAM 1500  
4th Gen Crew Cab



Toyota RAV4  
5th Gen



## ROOF RACK

### TARGET CONSUMER

- Off-road or outdoor enthusiast
- Adventure vehicle owner (Truck, SUV, CUV, Jeep, etc.)
- Values the rigor and quality of Yakima HD products

### FIT LISTINGS

- Each fit will be listed in all digital configurators
  - Listed along side tower and crossbar fits







## ROOF RACK

# RuggedLine HD

## LOCKNLOAD SYSTEM

- Designed and tested for off-road use
- Integrated fairing on all vehicle specific fits
- New fit development will continue
- MSRP's: \$449- \$679 (not including LNL)



Track Fit



"Taco Supreme"



CATEGORY	PRODUCT	NEW / TRANSITION
ROOF RACKS	RuggedLine 4Runner	NEW
ROOF RACKS	RuggedLine Tacoma	NEW
ROOF RACKS	RuggedLine Track	NEW
ROOF RACKS	RuggedLine Grand Cherokee	NEW
ROOF RACKS	RuggedLine RAM	NEW
ROOF RACKS	RuggedLine RAV4	NEW



TRUCK

# OverHaul MOLLE Panel

TRUCK RACK ACCESSORY







# OverHaul MOLLE Panel

## TRUCK RACK ACCESSORY

- Side-mounted panel for accessory mounting
- MOLLE style pattern that works with  
Recovery tracks | Shovel, Axe, Paddle Mounts  
Rotopax Mounts | Lights | Soft Pouches
- Works with OverHaul
- Will not replace SideBar accessories
- 2 SKU's, Short / 40" crossbar spread & Mid / 54"
- 80lb Weight limit (100% off-road rated)



# Sp24 Product List

## ROOF RACKS AND TRUCK



CATEGORY	PRODUCT	PART #	NEW / TRANSITION	MSRP
<b>ROOF RACKS</b>	RuggedLine HD 4Runner	8005065	NEW	\$ 679
<b>ROOF RACKS</b>	RuggedLine HD Tacoma	8005066	NEW	\$ 449
<b>ROOF RACKS</b>	RuggedLine HD Track Mount	8005067	NEW	\$ 499
<b>ROOF RACKS</b>	RuggedLine HD Grand Cherokee	8005068	NEW	\$ 449
<b>ROOF RACKS</b>	RuggedLine HD RAM	8005069	NEW	\$ 549
<b>ROOF RACKS</b>	RuggedLine HD RAV4	8005070	NEW	\$ 499
<b>TRUCK</b>	Truck MOLLE Panel, Short	8001178	NEW	\$ 199
<b>TRUCK</b>	Truck MOLLE Panel, Mid	8001179	NEW	\$ 279





**YAKIMA<sup>®</sup>**

**TAKE IT EASY<sup>™</sup>**



# S24 LAUNCH ALIGNMENT





# GTM S24 Milestones

Event	S24
Summer Sales Meeting	May 31 -June 2, 2023
Digital Showroom Live	June 1, 2023
SSM Follow Up Q&A	June 7, 2023
Grassroots Connect (GOA) Regional Show	June 12-15, 2023
ATS	February 15, 2024*



# Sell-In Tools



## S24 B2B Asset Deliverables

	Delivery Date
	6/1/2023
Dealer Workbook (Digital)	6/1/2023
Product Overview Videos (InsideScoop)	6/1/2023
Digital Showroom	6/1/2023
Print Collateral ( <u>New Format</u> Dealer Workbook)	6/1/2023
Price Lists (Digital)	6/1/2023
Product Guide (Digital/Print?)	2/15/2024
Merchandising/POP/Swag	2024

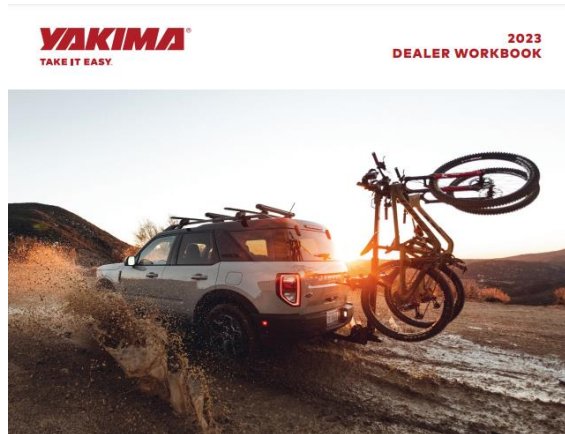





# First Impressions

## Trade Marketing

- Focusing on Trade Marketing, not just Consumer Marketing
- Elevated Content and Tool Kit for Sell-In
- Building Trust and Enticing Adventure
- Movie Magic: Prototypes
- Investments: CGI, Content, Showrooms



A dark, misty forest of evergreen trees, likely spruce or fir, filling the background. The trees are densely packed and their colors range from deep green to dark grey, creating a textured and atmospheric scene. A thin layer of mist or fog hangs between the trees, softening the background.

# Resources

---

**TOOLS FOR YOUR SUCCESS**



# showroom.yakima.com

- Note The Web Address
- Content Available On-Demand
  - Interactive Product Launch Catalog
  - Video Library
  - Digital Resource Download
  - Password Protected
- Dealer/Rep Access Continued
- Reset My Password Option Added
- Requesting Access: email me, use the request link on home page to self-register

**YAKIMA**  
TAKE IT EASY.

## SP24 Showroom

EXPLORE

Video Library →

SEE THE LINE

Key Products →

Digital Tools →

SEE OUR BRAND RESOURCES AND DOWNLOADS

OPEN SHOWROOM

BROWSE BY CATEGORY

CARGO

ROOF RACK

BIKE

**YAKIMA**

# Regional Show Support

- Yakima Invested In Providing Show Support Assets
- Tension Walls, Table Cloths. 3 –Hitch Bike Display Sent To Agencies
- Library of Tension-Walls, Drapes, and More Available For Check-Out
- Field Assets Via Order
- Planning Is Key!

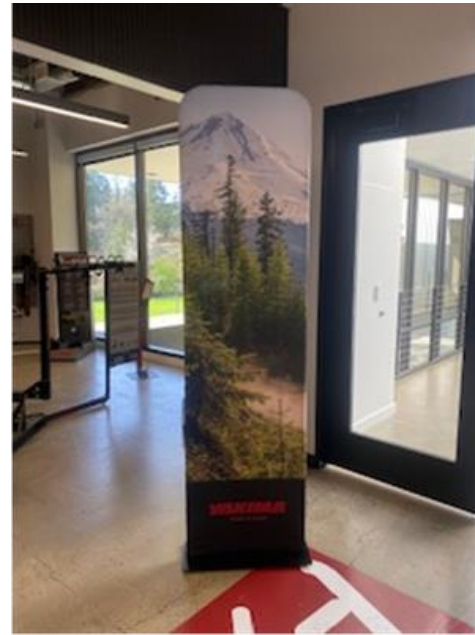

10' Tension Wall Double-Sided (Side 1 Top, Side 2 Bottom) Qty 1 of each available

PADDLE	TRUCK/OVERLAND	SNOW	ADVENTURE
#1	#2	#3	#4

10'X8' Drapes (3" hole pocket) Double-Sided (Side 1 Top, Side 2 Bottom) Qty 1 of each available

TRUCK/OVERLAND	ADVENTURE	BIKE	TRUCK/BEACH
#5	#6	#7	#8

10'X8' Drapes (3" hole pocket) Single-Sided (Side 1 Top, Side 2 blank) Qty 1 of each available

TRUCK/OVERLAND	EXO SYSTEM	BIKE VERTICAL
#9	#10	#11

#12 10'X3' Drape Side-Wall (3" hole pocket) Single-Sided Qty 2 available





# **MERCHANDISING**

---

# Tool Kit Review

- Tool Kit is live on B2B and shared links
  - Documents>Merchandising Information
- Kit Components:
  - Order Form
  - Merch, POP, Field Assets Catalog
  - Swag Catalog
  - Freestanding Display Build Simulators
  - Ordering Process Maps
  - Dealer Service Team Members
  - NEW- Inventory Report -> B2B Reports





# Where to find toolkit?

- Tool Kit is live on B2B
  - 2023 Merchandising Documents Folder
  - <https://yakima.hubsoft.com/documents/>
- Download from a Link:
  - *Sales rep* kit link
    - <https://we.tl/t-GQF1gf9Pnx>
  - How to share with *retailers*?
    - Send them this link:  
<https://we.tl/t-cpgofmjR1A>

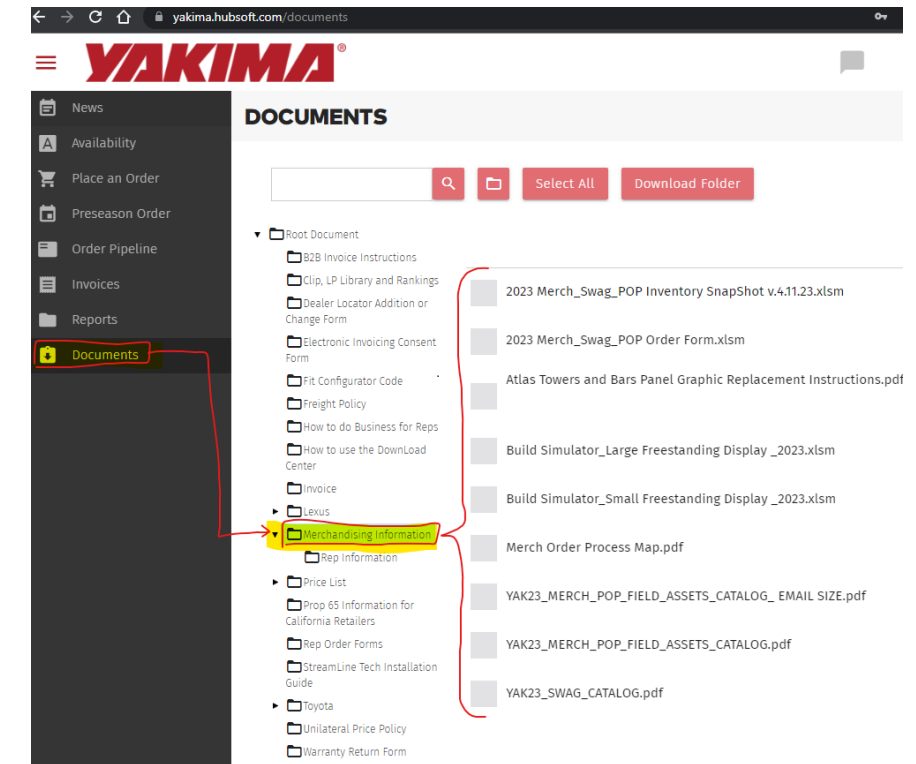
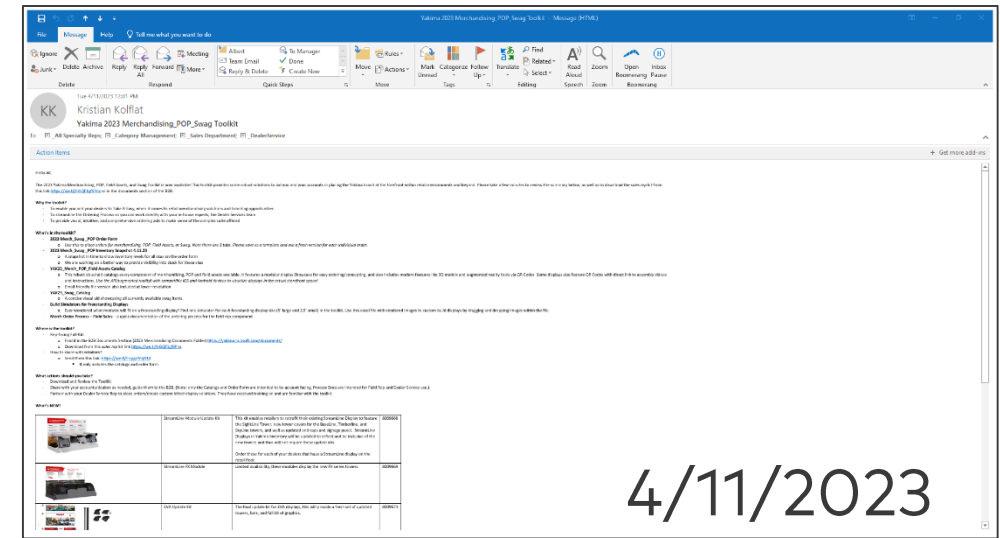







Image	Name	Description	Part #
	StreamLine Module Update Kit	This kit enables retailers to retrofit their existing StreamLine Display to feature the SightLine Tower, new tower covers for the BaseLine, Timberline, and SkyLine towers, and well as updated end caps and signage panel.	8009668
	StreamLine FX Module	Limited availability, these modules display the new FX series towers.	8009669
	EVA Update Kit	The final update kit for EVA displays, this will provide a fresh set of updated towers, bars, and full kit of graphics.	8009671



Image	Name	Description	Part #
	Cargo Graphics (updated)	For those who provided feedback on ship to list, the single SkyBox Family graphic has shipped direct to dealer, and all complete kits in inventory will be updated to be current.	NA
	RibCage Banner	Accounts buying into RibCage will be provided a banner	NA
	Atlas Update	<p>Pending final REI approval and timing, more info to follow on the execution of placing these into the field this month.</p> <p>In the interim, you should have received temporary graphic signs (may 2022) to replace damaged tower displays, instructions on how to replace are also located in the B2B documents folder</p>	NA

# 2024 Concepts



"Z" Structure for easy assembly and flat shipping



Wrap Around Graphic



# 2024 Concepts

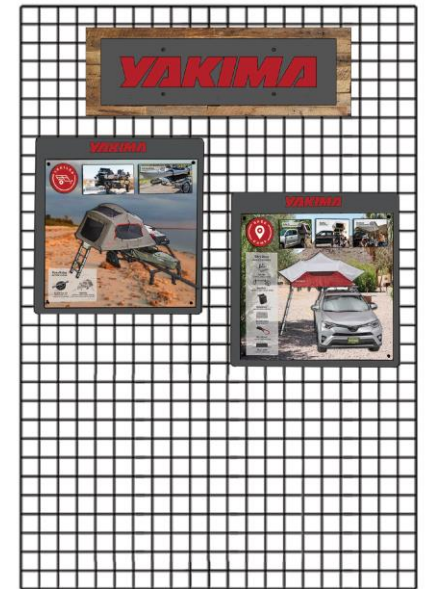
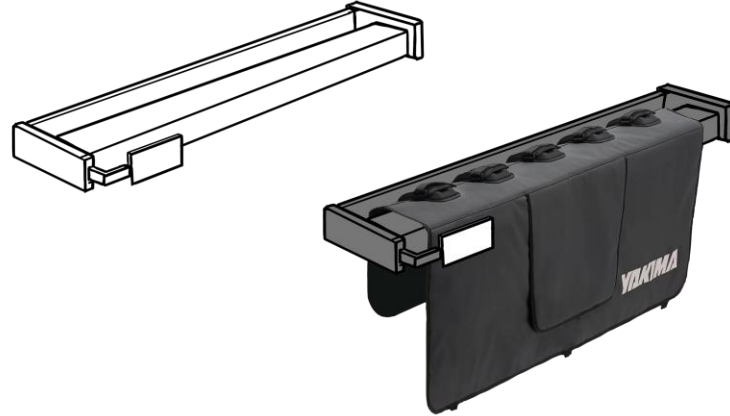



# **YAKIMA®**

## **TAKE IT EASY™**

